

## DESCRIPTION

FC7785 is a dual-band (Cellular/US-PCS) CDMA receiver diversity RF-to-baseband transceiver of FCI's zipRF™ family. It is a highly integrated chip working with a single power supply. Because zero-IF architecture is used for FC7785, additional components such as bulky IF SAW filters and other IF matching components are no longer required. FC7785 is featured to operate in the high data rate EVDO. Three-wired serial-to-parallel interface (SPI) protocol enables FC7785 to operate in the various modes. FC7785 contains complete dual-band receiver's main and diversity path such as LNA, down-conversion mixer, channel selection filter (CSF), Rx VCO, Rx PLL, and LO distribution block. FC7785 also contains complete dual-band transmitter path such as baseband amplifier, up-converter, RF variable-gain block, drive amplifier, Tx VCO, Tx PLL, and LO distribution block. FC7785 is optimized to have high SNR in 1x and EVDO Rev.A receive and transmit mode. FC7785 is available in 8 x 8 x 0.9 mm MLF package.

## APPLICATIONS

- Dual-band CDMA 1x/EVDO Rev.A diversity mobile phone or data card.

## REVISION HISTORY

- **Tentative** version release: Apr, 26, 2011
- **Preliminary** version release: Aug, 09, 2011
- **Preliminary** version release: Sep, 27, 2011
- **Preliminary** version release: Mar, 20, 2012
- **Preliminary** version release: Apr, 26, 2012
- **Preliminary** version release: May, 04, 2012
- **Preliminary** version release: Jan, 09, 2013

## FEATURES

- Single-chip dual-band (Cellular and US-PCS) receiver diversity transceiver without need of external LNA
- Low noise and highly linear LNA, mixer, and CSF for cellular/US-PCS CDMA
- Low noise, highly linear, wide dynamic range transmitter with baseband amplifier, up-converter, drive amplifier
- Automatic DC-offset calibration, filter calibration, VCO calibration
- Fully integrated low phase noise Rx, Tx, and Fractional-N PLL with fine frequency resolution
- Greater than 85-dB transmit power control
- Support 3-wired SPI protocol
- 8 x 8 x 0.9 mm MLF package

## BLOCK DIAGRAM

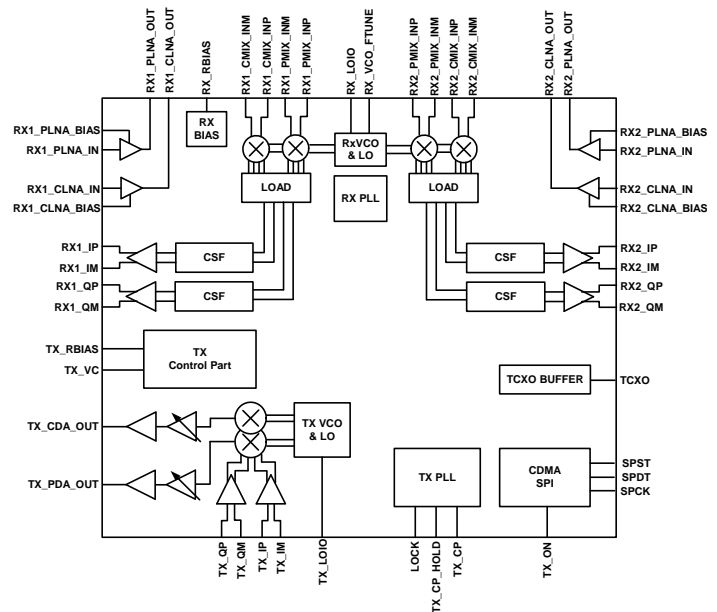

For latest specifications, technical questions and additional product information, visit website or e-mail

FCI Inc.  
11<sup>th</sup> Floor, Kins Tower, 25-1  
Jeongja-Dong, Bundang-Gu,  
Sungnam City, Gyunggi-do,  
463-811, KOREA

Website: <http://www.fci.co.kr>  
E-mail: [info@fci.co.kr](mailto:info@fci.co.kr)  
Phone: 82-31-711-6444  
Fax: 82-31-711-0313